

Schoriederstrasse

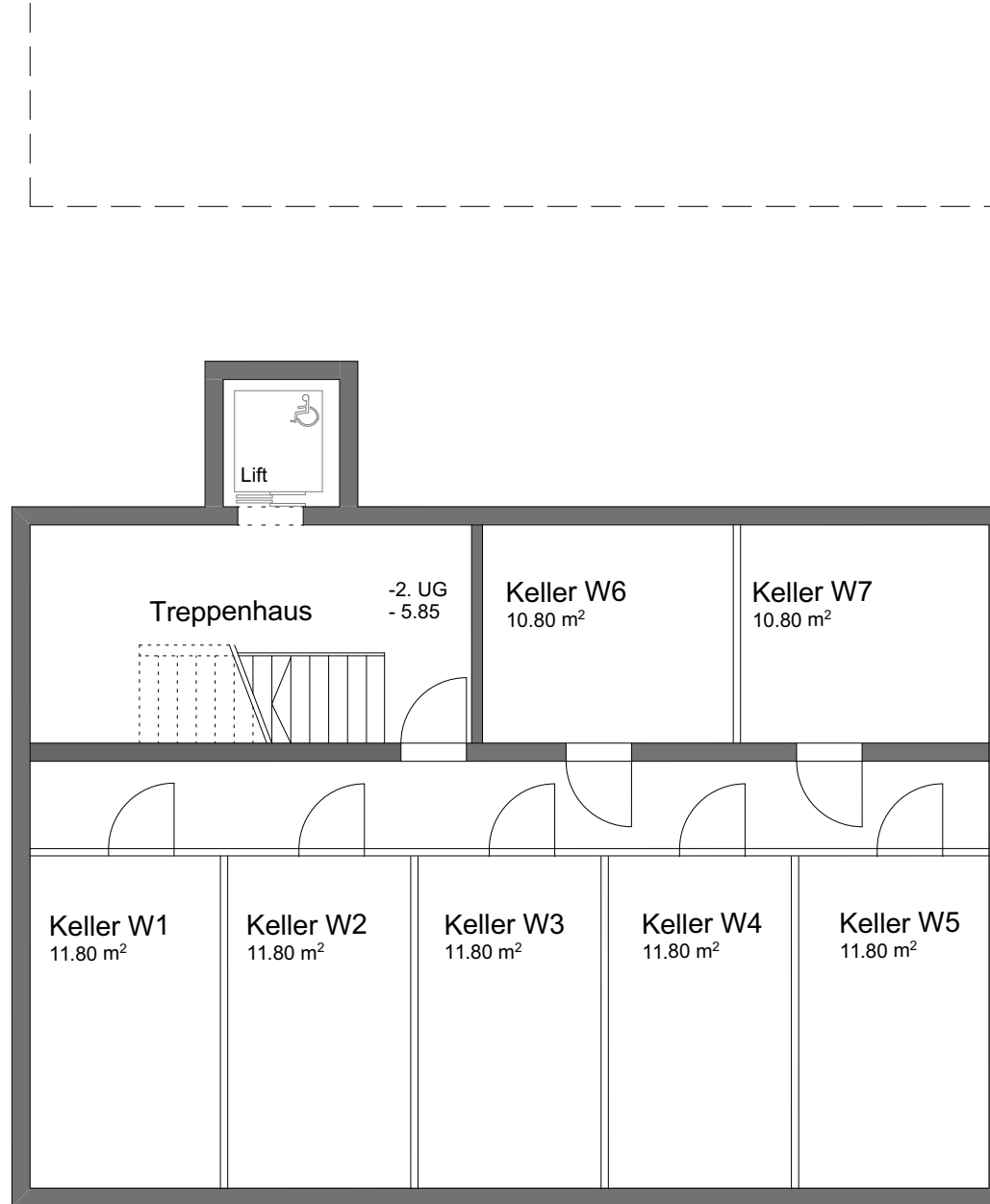

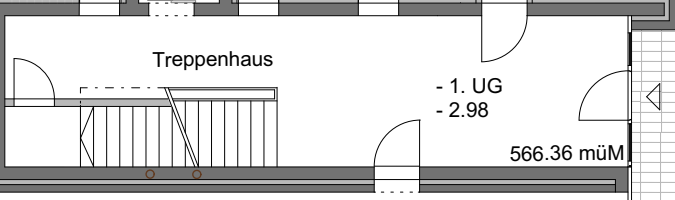
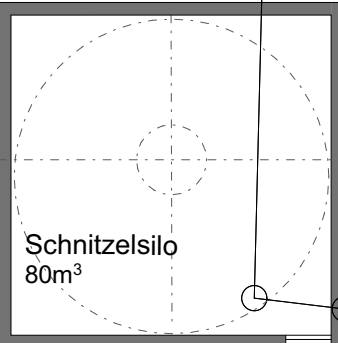
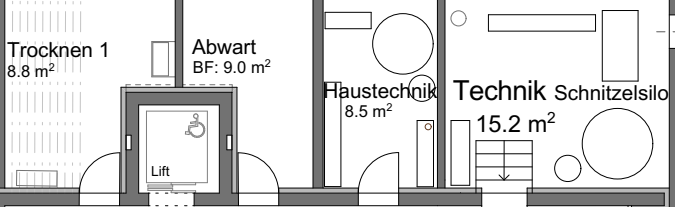
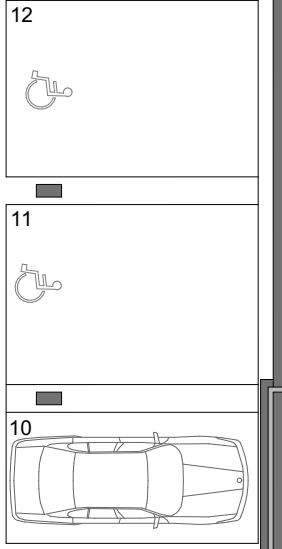
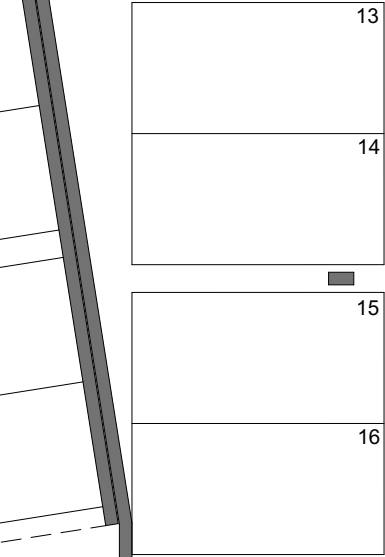
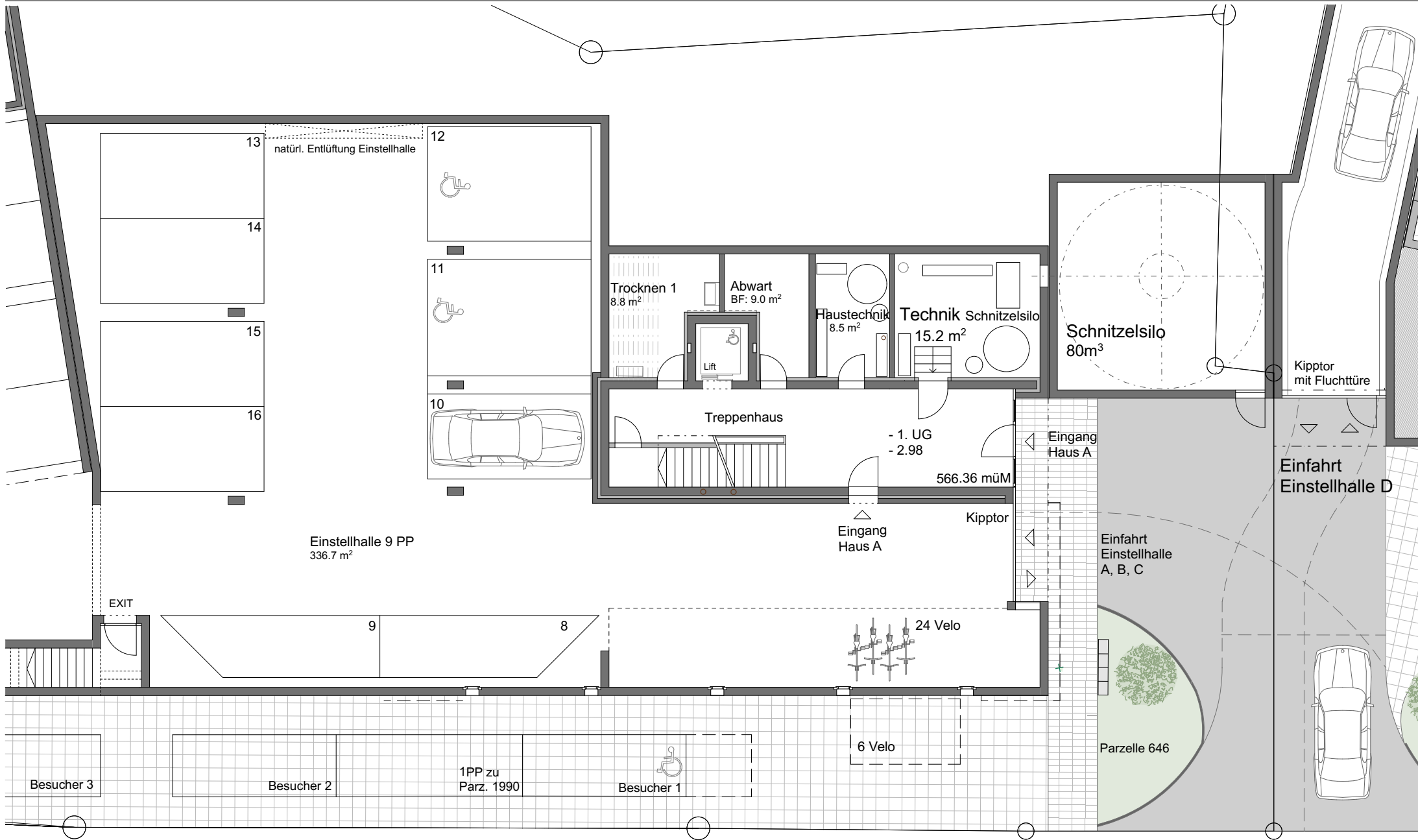

Einstellhalle 9 PP
336.7 m²

566.36 müM

Einfahrt
Einstellhalle
A, B, C

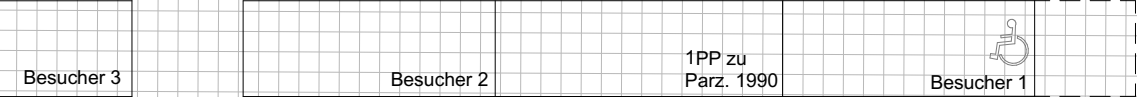
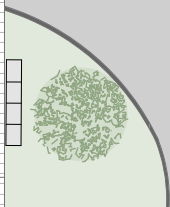
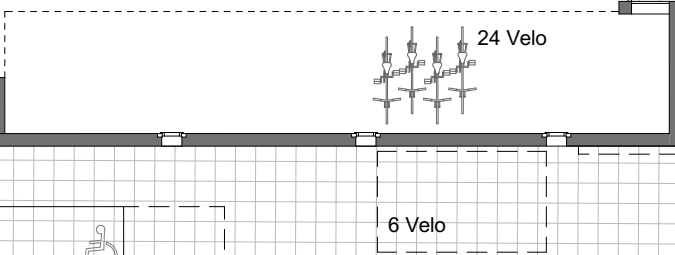
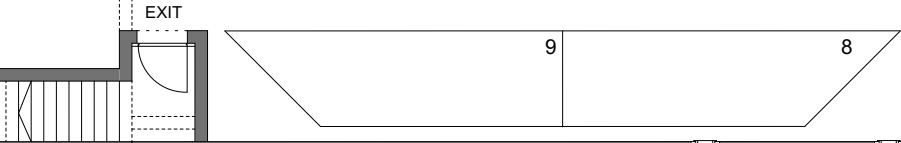

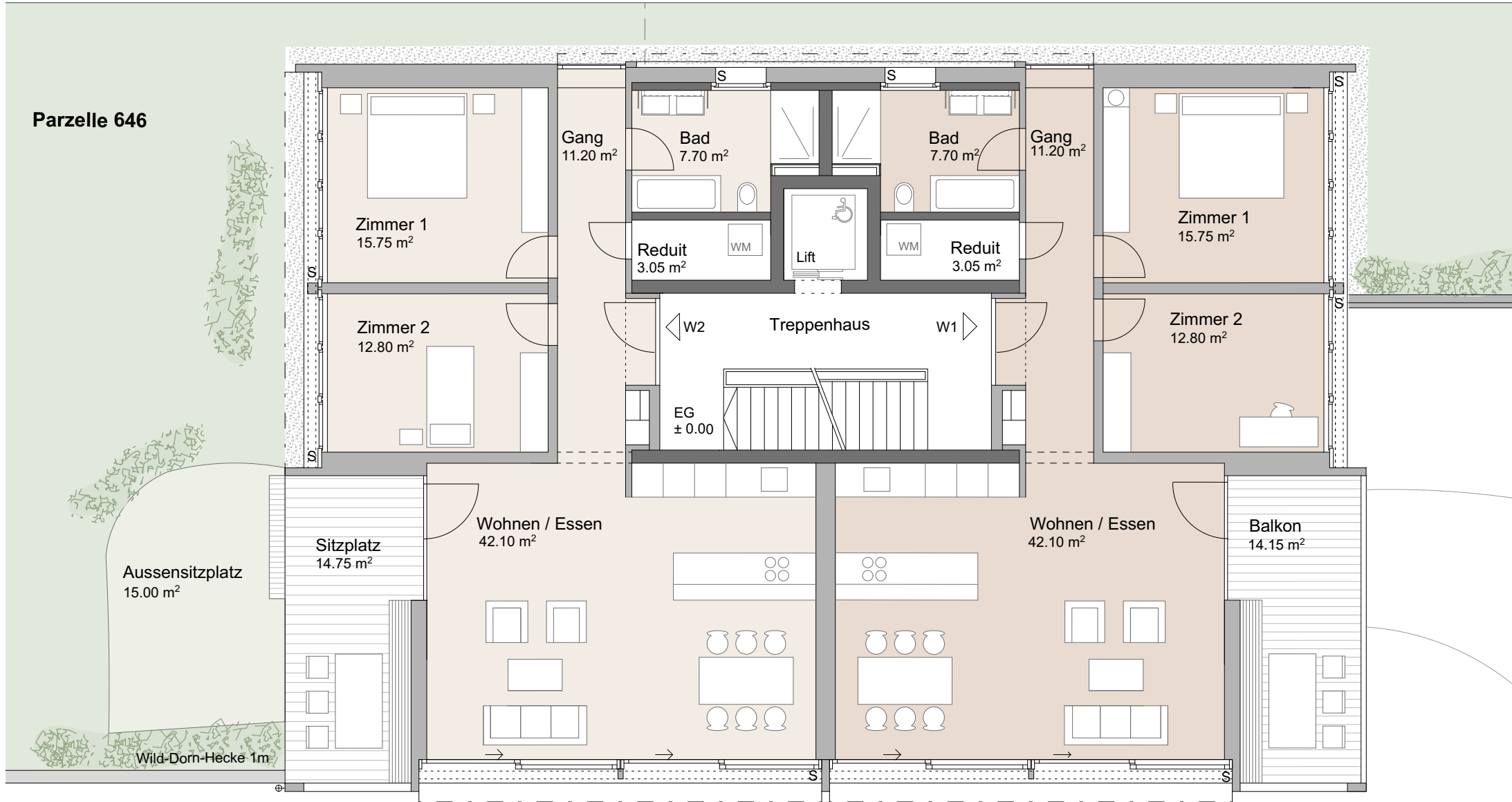

W2_EG
3.5 Zi Whg
Nettowoohnfläche 89.90 m²
Nebennutzfläche 3.05 m²

W1_EG
3.5 Zi Whg
Nettowoohnfläche 89.90 m²
Nebennutzfläche 3.05 m²

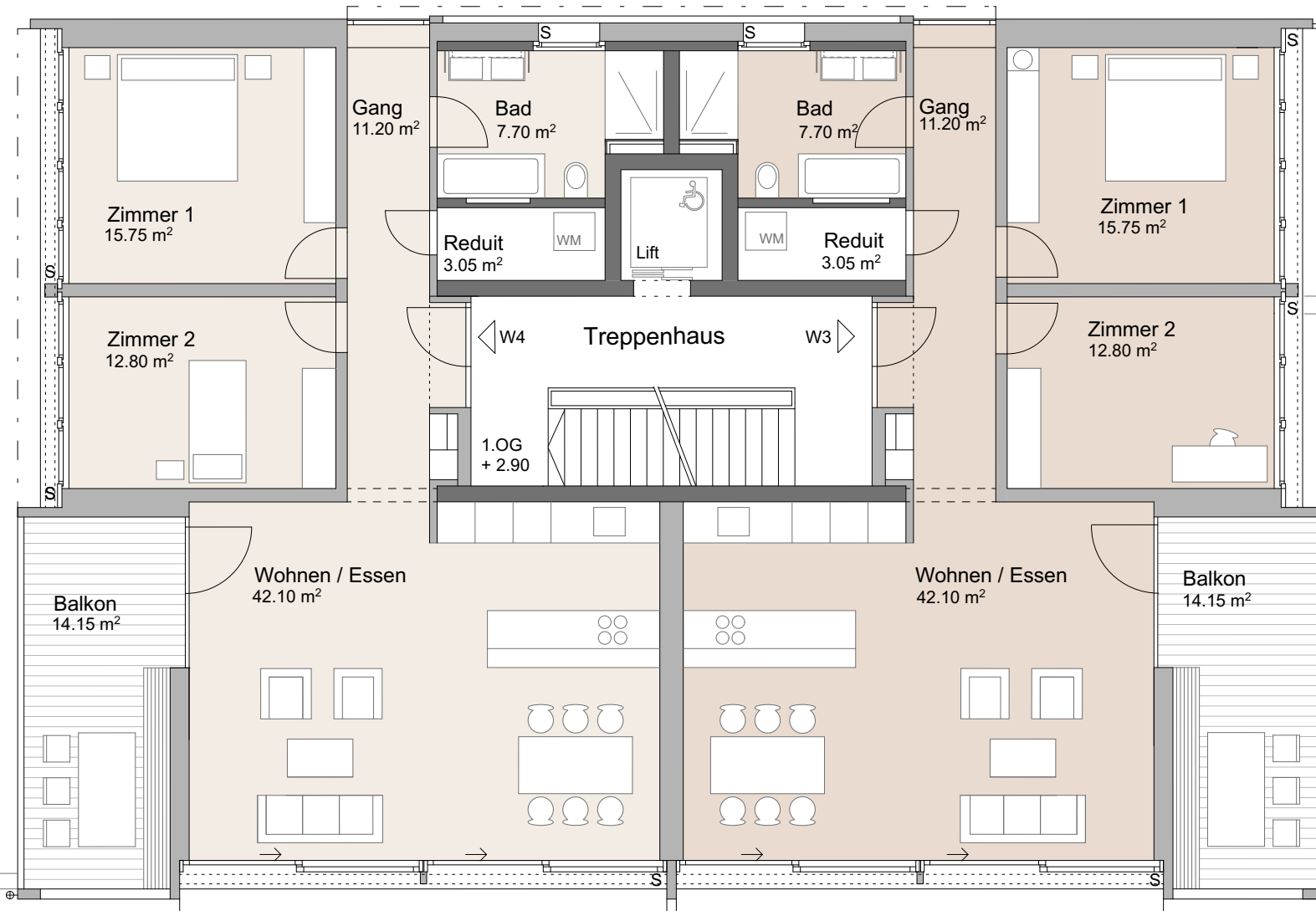

W4_1.OG
 3.5 Zi Whg
 Nettowohnfläche 89.90 m²
 Nebennutzfläche 3.05 m²

W3_1.OG
 3.5 Zi Whg
 Nettowohnfläche 89.90 m²
 Nebennutzfläche 3.05 m²

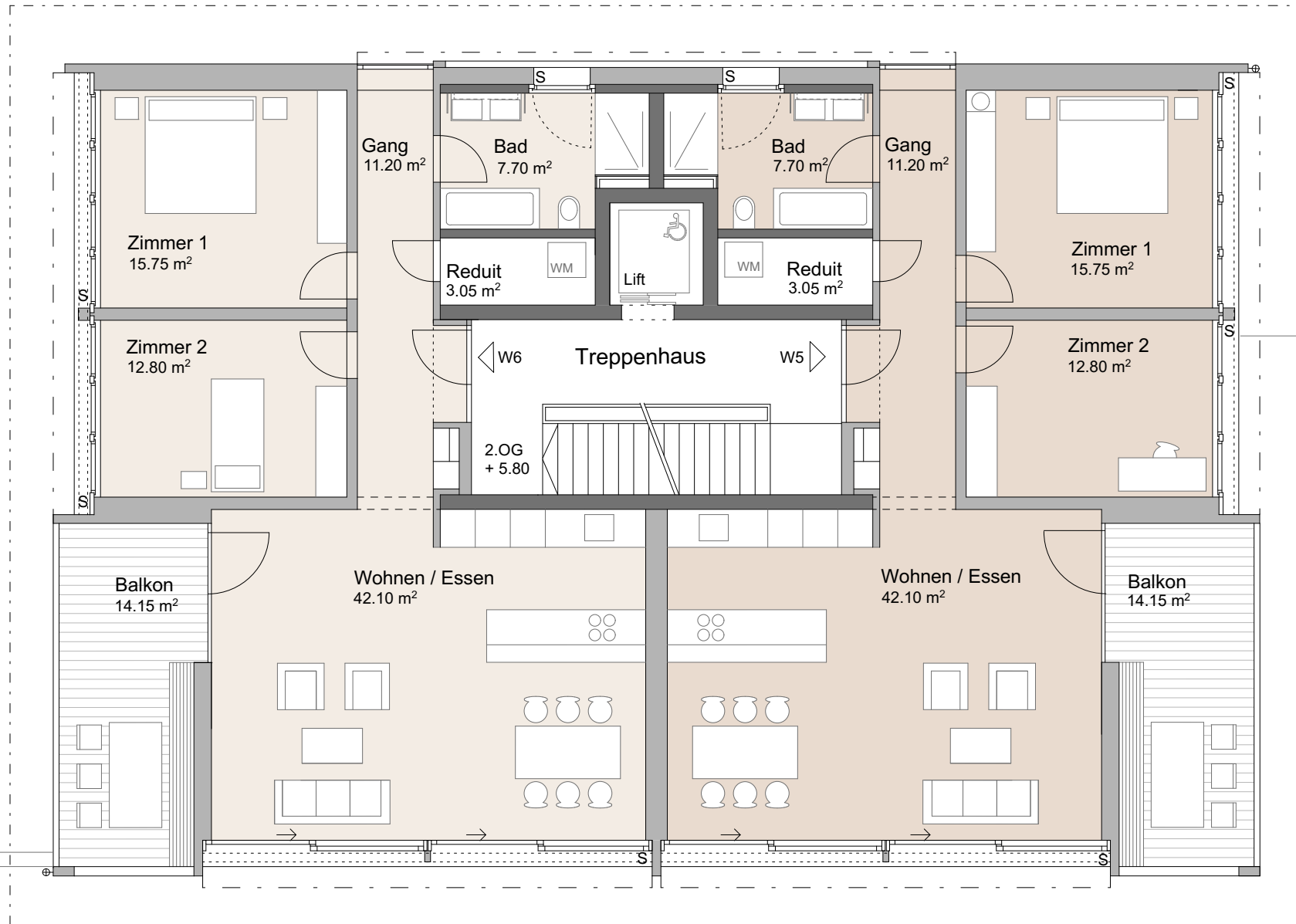

W6_2.OG
 3.5 Zi Whg
 Nettowohnfläche 89.90 m²
 Nebennutzfläche 3.05 m²

W5_2.OG
 3.5 Zi Whg
 Nettowohnfläche 89.90 m²
 Nebennutzfläche 3.05 m²

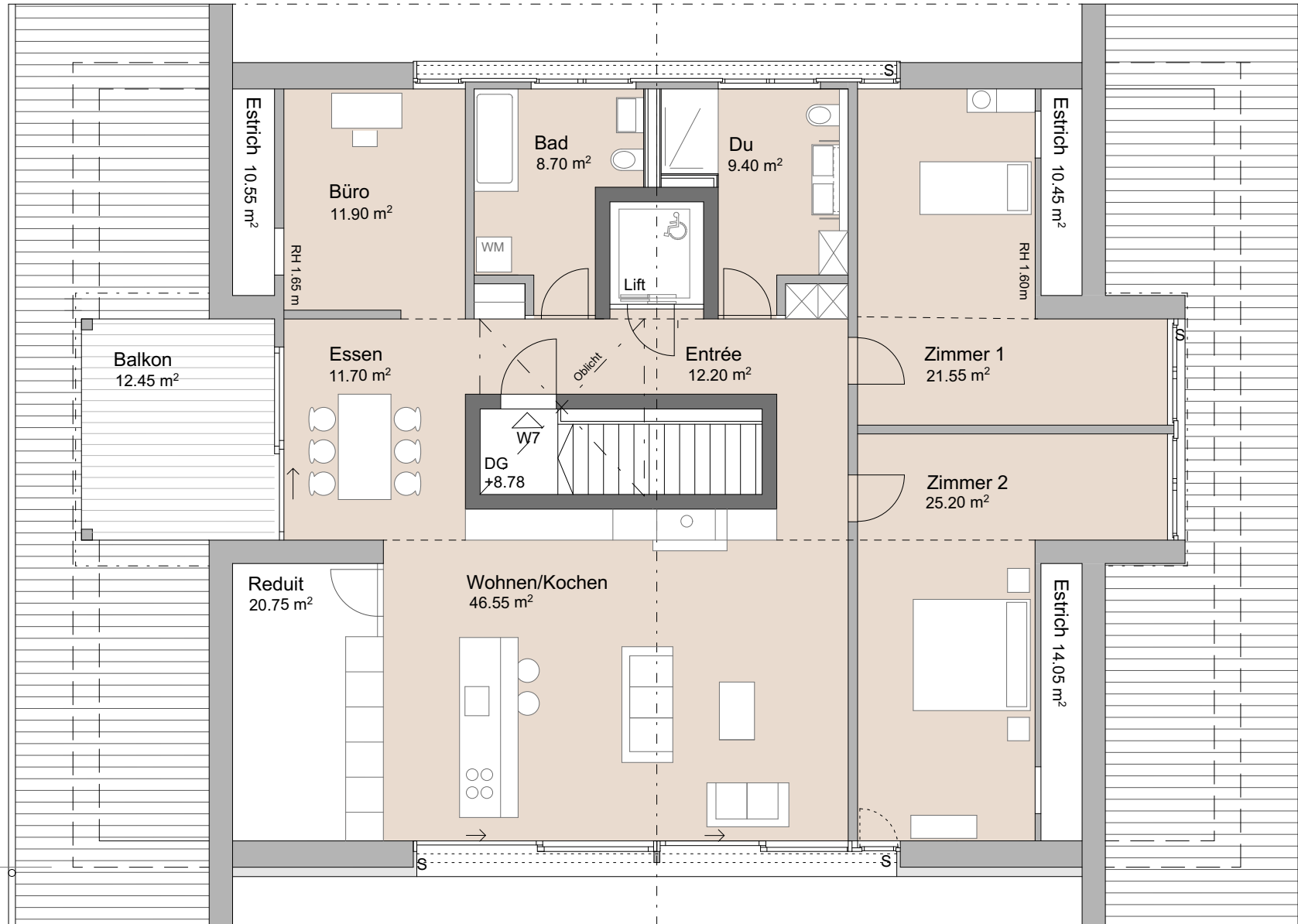

■ W7_DG
4.5 Zi Whg
Nettowoohnfläche 147.35 m²
Nebennutzfläche 55.80 m²

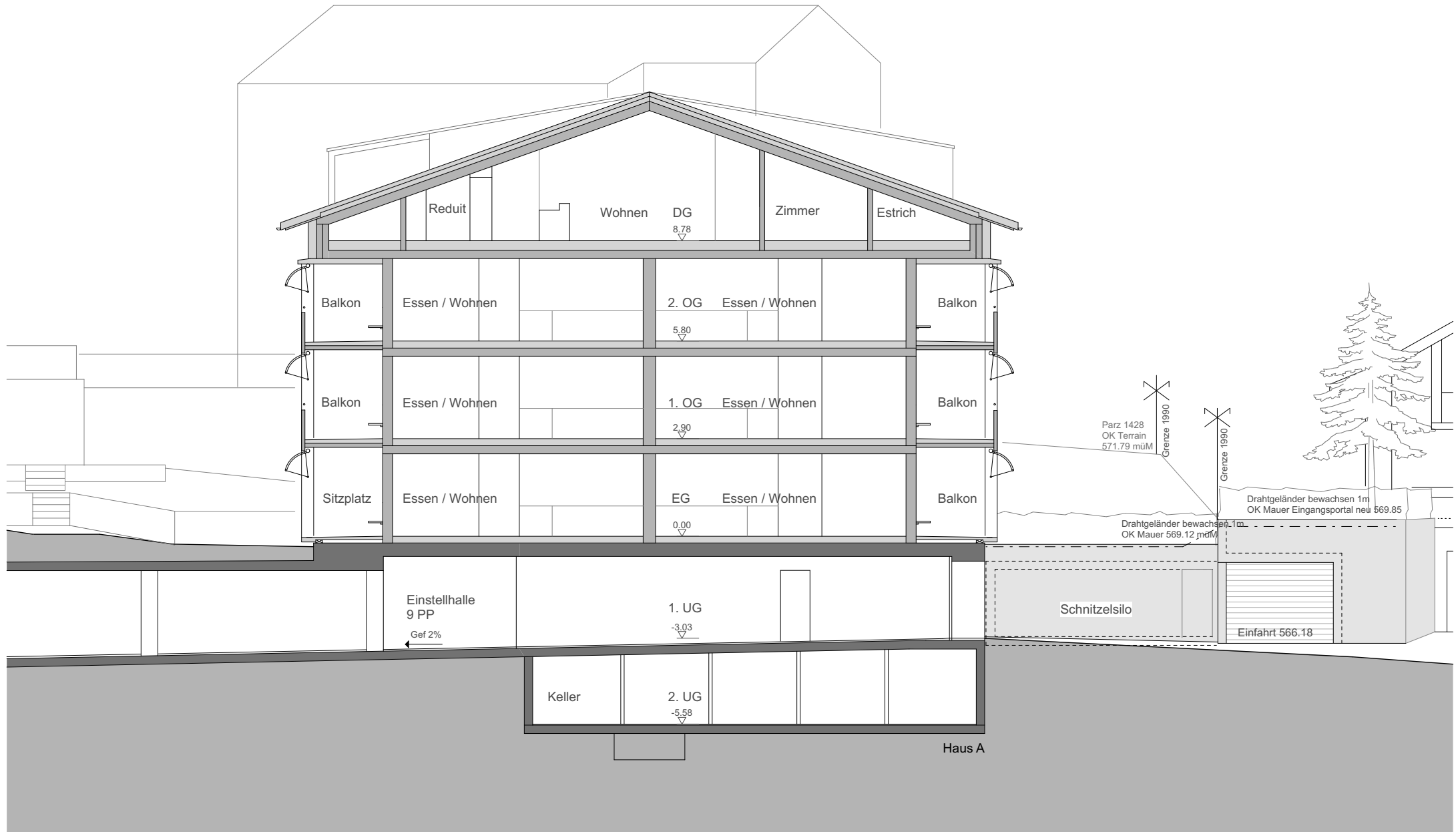

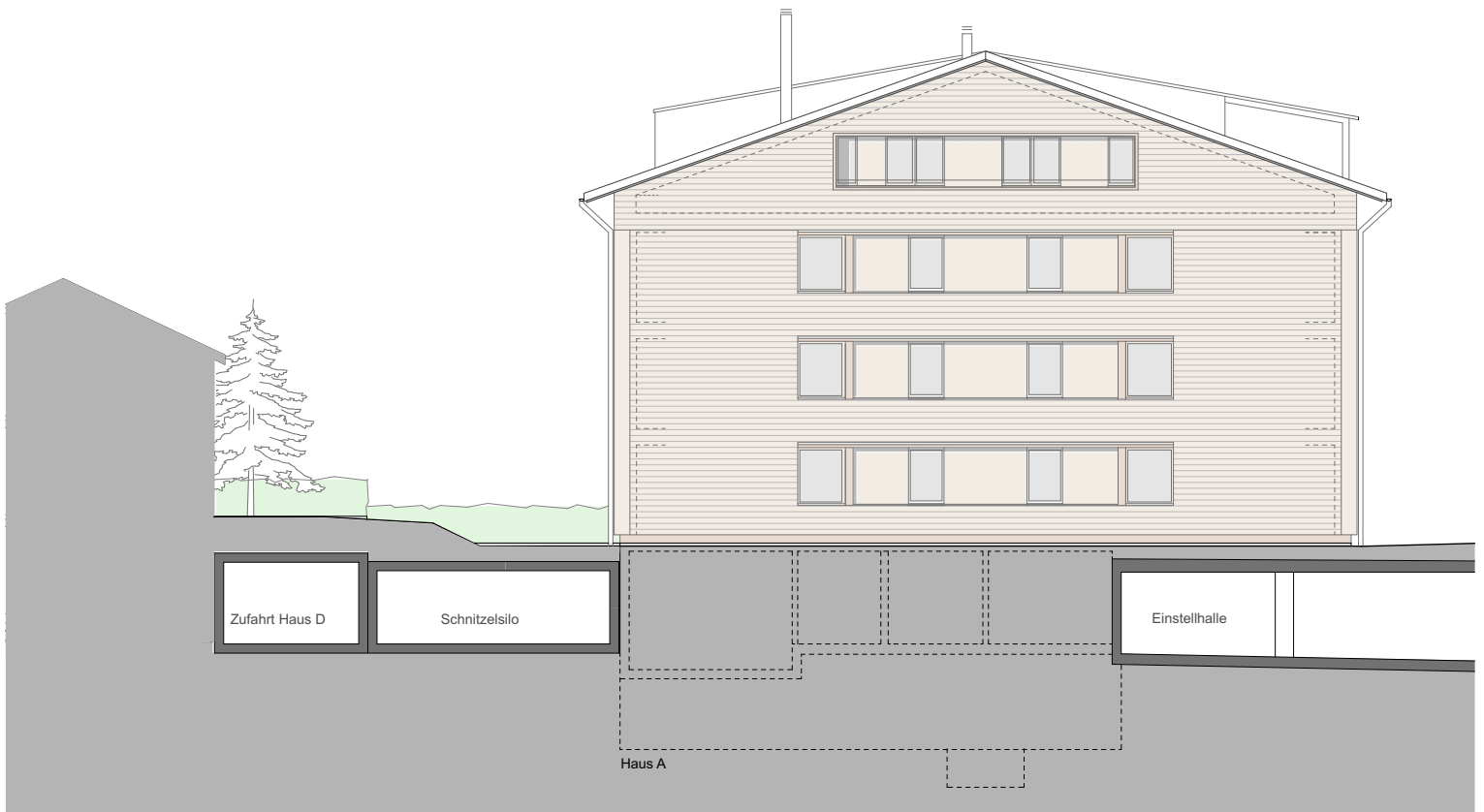

Nordfassade

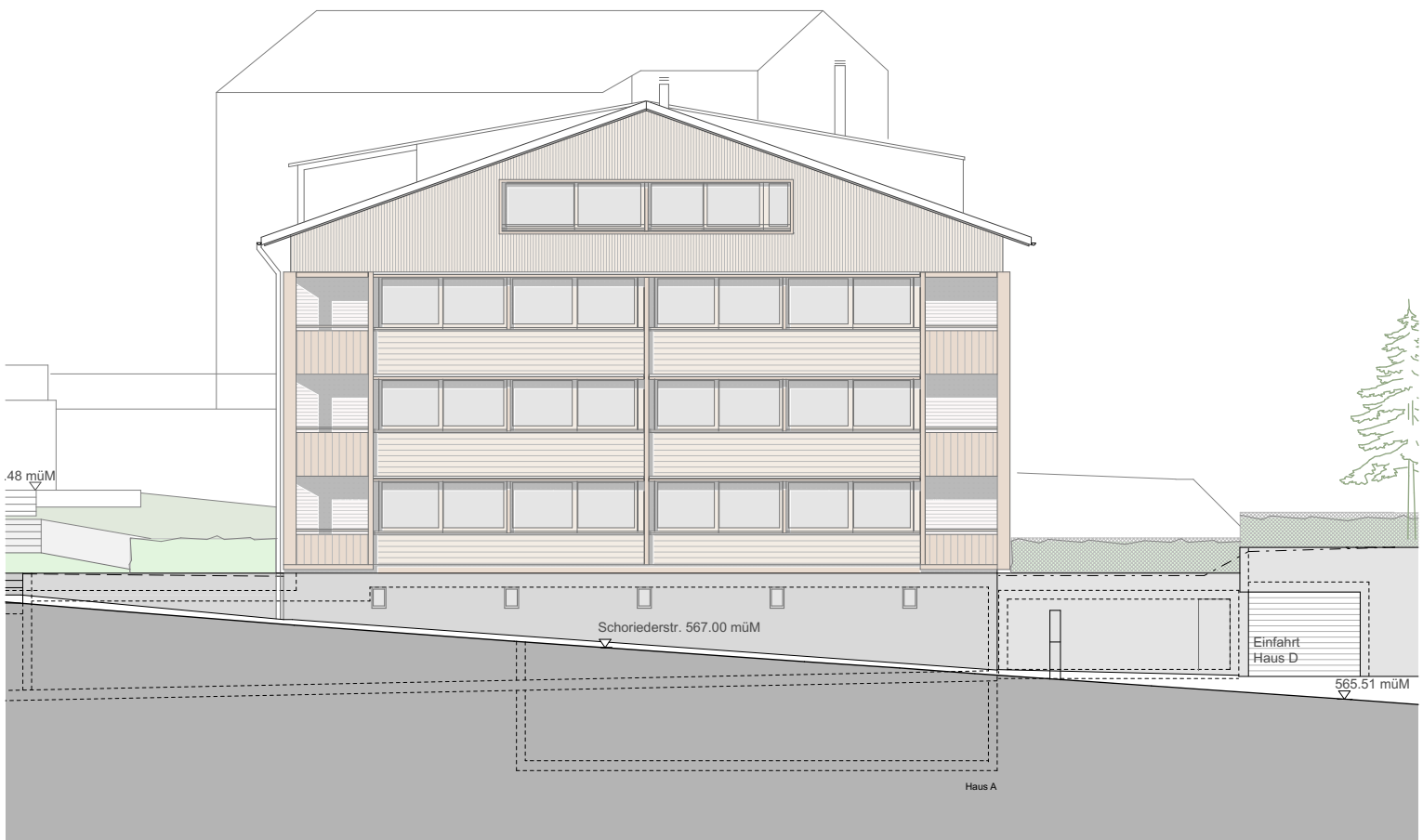

Südfassade

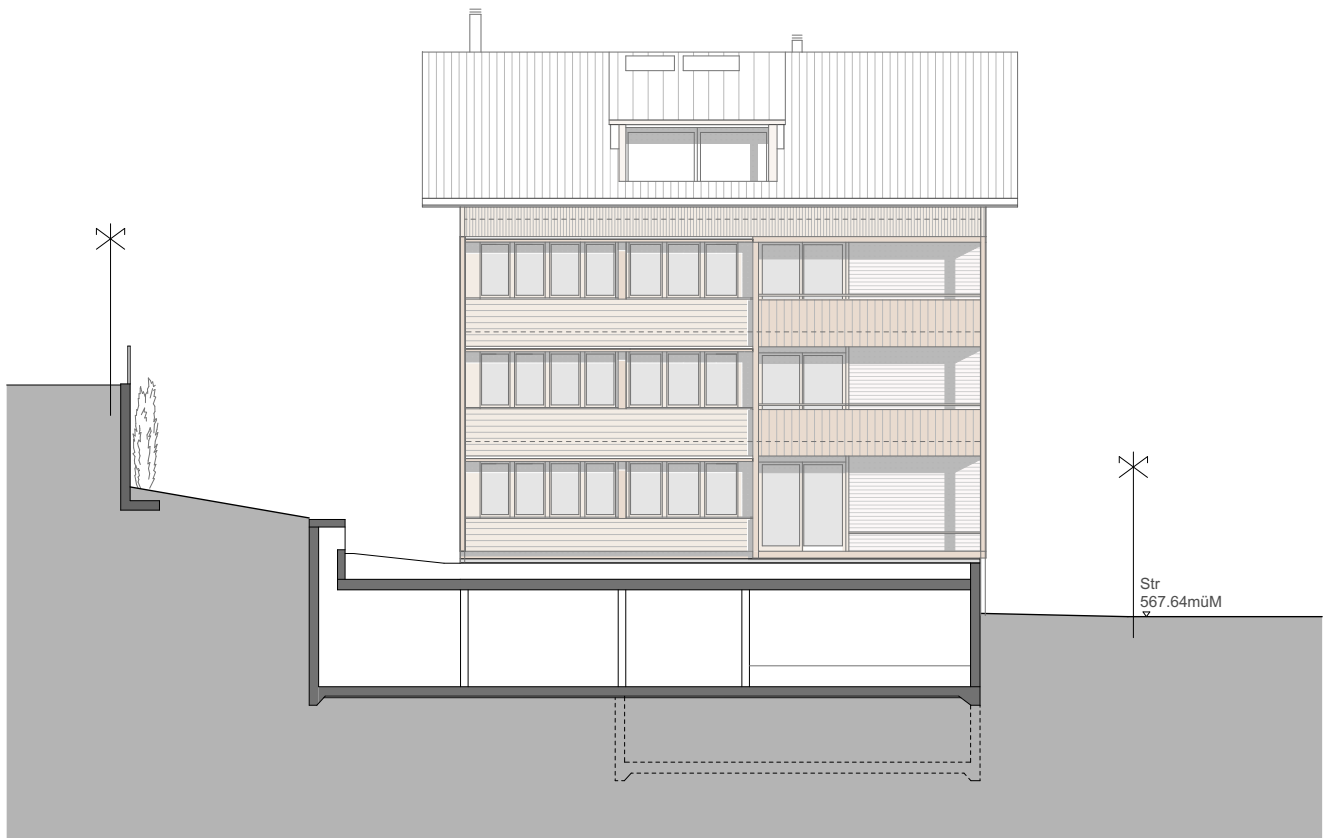

Westfassade

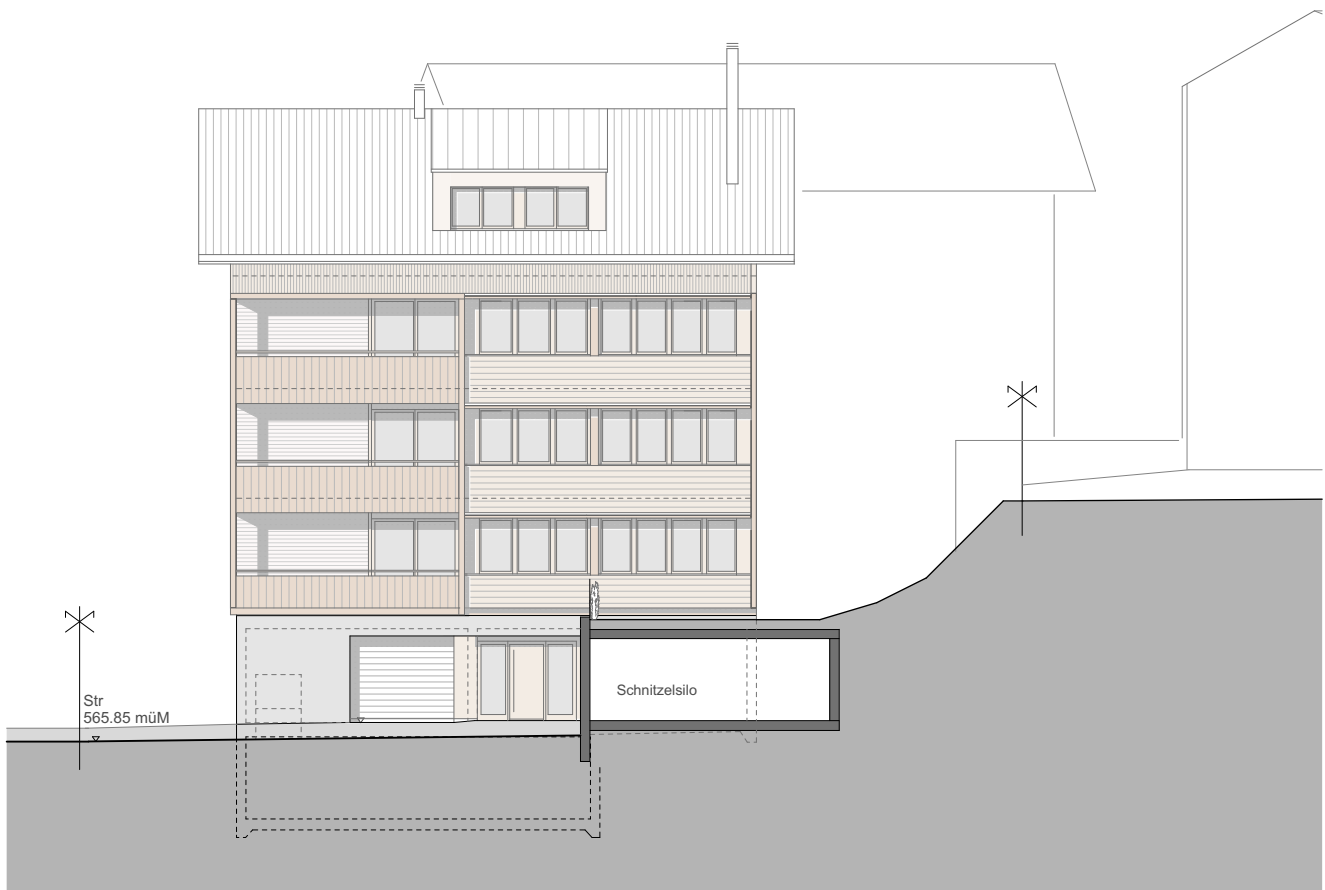

Ostfassade